

# ZIKA

## OWNER'S MANUAL

I-200c Premium/ I-250c



# CONTENTS

1. Contents .....	1
2. Safety warning .....	2
3. Machine description .....	3
4. Technical parameters table .....	4
5. Installation instruction .....	5
6. Operation instruction .....	6
7. Panel function instruction .....	7
8. Notes or preventive measures .....	8
9. Questions to be run into during welding .....	9
10. Maintenance .....	9
11. Troubleshooting and fault finding .....	10

---

## SAFETY WARNING

---



**On the process of welding or cutting, there will be possibility of injury, so please take protection into consideration during operation. For more details please review the Operator Safety Guide, which complies with the preventive requirements of the manufacturer.**

### **Electric shock——May lead to death !!**

- Set the earth fitting according to applying standard.
- Forbidden to touch the bare electric parts and electrode with uncovered skin, wet gloves or clothes.
- Make sure you are insulated from the ground and the workshop.
- Make sure you are in safe position.

### **Gases and fumes——May be harmful to health!**

- Keep your head out of the gases and fumes.
- When arc welding, ventilators or air extractors should be used to avoid breathing gases.

### **Arc rays——Harmful to your eyes, burn your skin.**

- Wear suitable protective mask, light filter and protective garment to protect eyes and body.
- Prepare suitable protective mask or curtain to protect looker-on.

### **Fire**

- Welding spark may cause fire, make sure there is no tinder stuff around the welding area.

### **Noise——Excessive noises will be harmful to hearing .**

- Use ear protector or others means to protect ear.
- Warn looker-on that noise is harmful to hearing.

### **Malfunction——When trouble happens, contact with authorized professionals**

- If trouble happens during installation and operation, please follow this manual instruction to check up.
- If you fail to fully understand the manual, or fail to solve the problem with the instruction, you should contact the suppliers or the service center for professional help.



### **WARNING!**

**Creepage-protecting switch should be added when using the machine!!!**

---

## MACHINE DESCRIPTION

---

The welding machine is a rectifier adopting the most advanced inverter technology.

The development of inverter gas-shielded welding equipment benefits from the development of the inverter power supply theory and components. Inverter gas-shielded welding power source utilizes high-power component MOSFET to transfer 50/60Hz frequency up to 100KHz , then reduce the voltage and commutate, and output high-power voltage via PWM technology. Because of the great reduce of the main transformer's weight and volume; the efficiency increases by 30%. The appearance of inverter welding equipment is considered to be a revolution for welding industry.

The welding power source can offer stronger, more concentrated and more stable arc. When stick and work piece get short, its response will be quicker. It means that it is easier to design into welding machine with different dynamic characteristics, and it even can be adjusted for specialty to make arc softer or harder.

MMA welding machine has the following characteristics: effective, power saving, compact, stable arc, good welding pool, high no-load voltage, and good capacity of force compensation and multi-use. It can weld stainless steel, alloy steel, carbon steel, copper and other color metal. It can apply to electrode of different specifications and materials, including acidity, alkalescency, and fibre. It can apply in high altitude, the open air and inside and outside decoration. Compared with the same products of home and abroad, it is compact in volume, light in weight, easy to install and operate.

Thanks for purchasing our product and hope for your precious advice. We will dedicate to produce the best products and offer the best service.



### **WARNING!**

**The machine is mainly used in industry. It will produce radio wave, so the worker should make fully preparation for protection.**

---

## TECHNICAL PARAMETERS TABLE

---

Model Parameters	I-200c Premium	I-250c
Power voltage (V)	1phase AC220V ±15%	3 phase AC380V ±15%
Frequency (Hz)	50/60	50/60
Rated input current (A)	43.6	14.4
No-load voltage (V)	70	67
Output current (A)	29-200	20-250
Rated output voltage (V)	28	30
Force range (A)	----	0-100
Duty cycle (%)	60	60
No-load loss (W)	40	60
Efficiency (%)	80	85
Power factor	0.73	0.93
Insulation grade	F	F
Housing protection grade	IP21	IP21
Weight (kg)	8	17.5
Dimensions (mm)	375×155×232	480×204×303

---

## INSTALLATION INSTRUCTION

---

The machine is equipped with power voltage compensation equipment. When the power voltage fluctuation is between  $\pm 15\%$  of rated voltage, it still can work normally.

When the machine is used with long cables, in order to prevent voltage from going down, bigger section cable is suggested. If the cable is too long, it may affect the performance of the power system. So cables of configured length are suggested.

1. Make sure the intake of the machine is not blocked or covered to avoid malfunction of cooling system.
2. Ground the cables with section area no less than  $6\text{mm}^2$  to the housing, the way is connecting screw in the back of the power source to ground device .
3. Correctly connect the arc torch or holder according to the sketch. Make sure the cable, holder and fastening plug have been connected with the ground. Put the fastening plug into the fastening socket at the “-” terminal and fasten it clockwise.
4. Put the fastening plug of the cable to fastening socket of “+” terminal at the front panel, fasten it clockwise, and the earth clamp at the other terminal clamps the work piece.
5. Please pay attention to the connecting terminal, DC welding machine has two connecting ways: positive connection and negative connection. Positive connection: holder connects with “-” terminal, while work piece with the “+” terminal. Negative connection: work piece with the “-” terminal, holder with the “+” terminal. Choose suitable way according to the working situation. If unsuitable choice is made, it will cause unstable arc, more spatters and conglutination. If such problems occur, please change the polarity of the fastening plug.
6. According to input voltage grade, connect power cable with power supply box of relevant voltage grade. Make sure no mistake is made and make sure the voltage difference is among permission range. After the above job, installation is finished and welding is available.

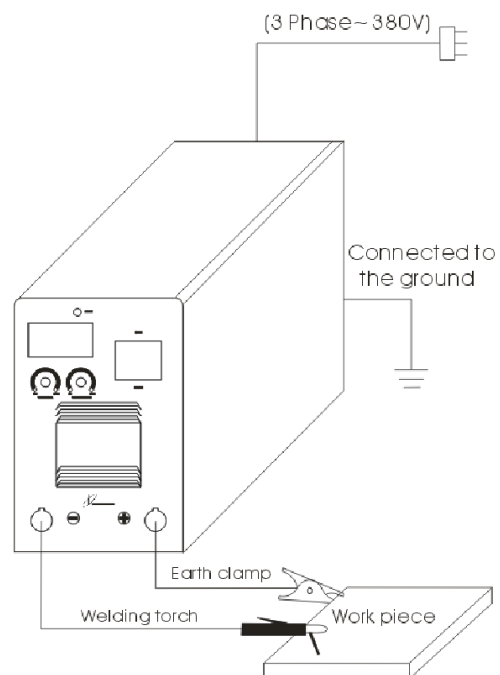

**If distance of work piece and machine is too far (50-100m), and the cables (torch cable and earth cable) are too long, please choose cable of bigger section to minimize the reduction of the voltage.**

---

## OPERATION INSTRUCTION

---

1. Turn on the power switch, the screen will show set current value and ventilator is beginning to run.
2. Adjust knobs of welding current and arc-striking push, make welding function complies with demands.
3. Generally, welding current is adequate to welding electrode according with as following:

Specification	φ 2.5	φ 3.2	φ 4.0	φ 5.0
Current	70-100A	110-140A	170-220A	230-280A

4. Knob of arc-striking drive is use to adjust welding function, specially in low current arrange, that is cooperated with knob of welding current adjustment, they may adjust current of arc striking and be out of control of knob of welding current adjustment .So machine can grain powerful energy and push current can achieve effect that may .
5. If the VRD equipment is installed in the machine. When the switch of back panel is put "ON" position, the VRD indictor is lit, and when the switch is put "OFF" position, the VRD indicator is off, then the no-load voltage is 67V.switch of VRD is put inside the machine, with the "on" condition. the no-load voltage changes to be less than 15V, which is safe for people.
6. The welding machine has been coordinated with remote control device:
  - 1) Check the switch position of remote control device before operation .If the switch is on "OFF" Position then is out of remote control. Switch is on "ON" position then is using remote control device.
  - 2) Insert plug of remote control in socket of remote control correctly and tighten firmly in order to prevent poor contact.
  - 3) If remote control device is not used, make sure the switch is on "OFF" position, or welding current will not be able to be adjusted on panel.



### **WARNING!**

**Before connecting operation please make sure all the power is turned off. The right order is to connect the welding cable and ground cable to the machine first, and make sure they are firmly connected and then put the power plug to the power source.**

# PANEL FUNCTION INSTRUCTION

## I-200c Premium FRONT PANEL

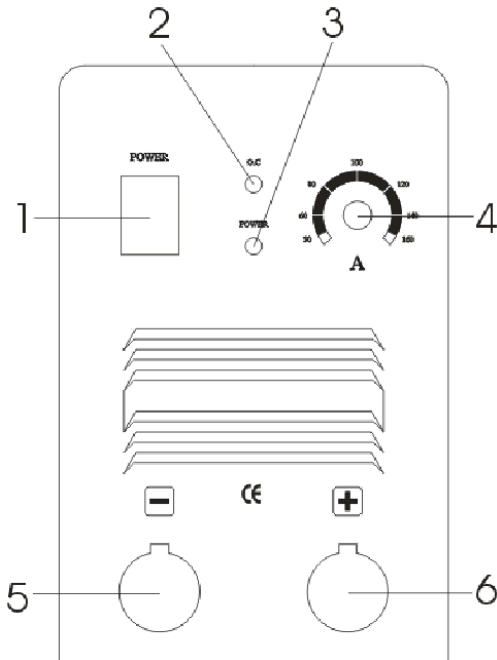

1	Power switch
2	Abnormal indicator
3	Power indicator
4	Welding current adjustment
5	Negative output terminal
6	Positive output terminal

## I-250c FRONT PANEL

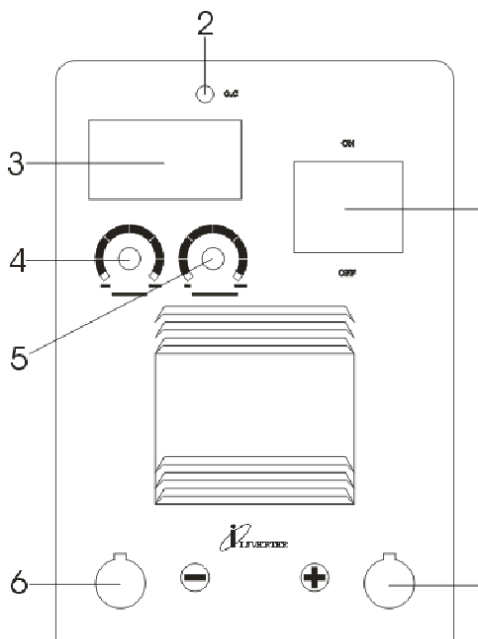

1	Power switch
2	Abnormal indicator
3	Current meter
4	Welding current adjustment
5	ARC force current adjustment
6	Negative output terminal
7	Positive output terminal

The panel picture above is for reference only. If any difference with the real machine, please follow with the real machine.





### 1. Environment

- 1) The machine should be operated in dry environments with humidity levels of max 90%.
- 2) Ambient temperature should be between -10 to 40 degrees centigrade.
- 3) Avoid welding in sunshine or drippings. Do not let water infiltrate the machine.
- 4) Avoid welding in dust area or the environment with corrosive gas.
- 5) Avoid gas welding in the environment with strong airflow.

### 2. Safety norms

The welding machine is installed with protection circuit of over voltage, over current and over heat. When voltage, output current and temperature of machine exceed the required standard, welding machine will stop working automatically. However, overuse (such as over voltage) will still result in damage to the welding machine. To avoid this, the user must pay attention to the following.

#### 1) **The working area is adequately ventilated !**

The welding machine is powerful machine, when it is being operated, it generated by high currents, and natural wind will not satisfy machine cool demands. So there is a fan in inner-machine to cool down machine. Make sure the intake is not in block or covered, it is 0.3 meter from welding machine to objects of environment. User should make sure the working area is adequately ventilated. It is important for the performance and the longevity of the machine.

#### 2) **Do not over load !**

The operator should remember to watch the max duty current (Response to the selected duty cycle). Keep welding current is not exceed max duty cycle current. Over-load current will damage and burn up machine.

#### 3) **No over voltage !**

Power voltage can be found in diagram of main technical data. Automatic compensation circuit of voltage will assure that welding current keeps in allowable range. If power voltage is exceeding allowable range limited, it will damage to components of machine. The operator should understand this situation and take preventive measures.

4) There is a grounding screw behind welding machine, with a grounding marker on it. Before operation , welding crust must be grounded reliable with cable which section is over 6 square millimeter, in order to prevent from static electricity , and accidents because of electricity leaking.

5) If welding time is exceeded duty cycle limited, welding machine will stop working for protection. Because machine is overheated, temperature control switch is on "ON" position and the indicator light is red. In this situation, you don't have to pull the plug, in order to let the fan cool the machine. When the indicator light is off, and the temperature goes down to the standard range, it can weld again.

---

## QUESTIONS TO BE RUN INTO DURING WELDING

---

Fittings, welding materials, environment factor, supply powers maybe have something to do with welding. User must try to improve welding environment.

### **A. Arc-striking is difficult and easy to pause**

1. Make sure quality of tungsten electrode is high .
2. If the electrode is not dried, it will cause unstable arc, welding defect increases and the quality is down.
3. If use extra-long cable, the output voltage will decrease, so please shorten the cable

### **B. Output current not to rated value:**

When power voltage departs from the rated value, it will make the output current not matched with rated value; when voltage is lower than rated value, the max output may lower than rated value.

### **C. Current is not stabilizing when machine is been operating:**

It has something with factors as following :

1. Electric wire net voltage has been changed .
2. There is harmful interference from electric wire net or other equipment

### **D. Too much spatter when use MMA welding,**

1. Maybe current is too big and stick's diameter is too small.
2. Output terminal polarity connection is wrong, it should apply the opposite polarity at the normal technics, which means that the stick should be connected with the negative polarity of power source, and work piece should be connected with the positive polarity. So please change the polarity.

---

## MAINTENANCE

---

1. Remove dust by dry and clean compressed air regularly, if welding machine is operating in environment where is polluted with smokes and pollution air, the machine need remove dust every month.
2. Pressure of compressed air must be within the reasonable range in order to prevent damaging to small components of inner-machine.
3. Check internal circuit of welding machine regularly and make sure the circuit connections are connected correctly and tightly (especially plug-in connector and components). If scale and rust are found, please clean it, and connect again tightly.
4. Prevent water and steam from entering into the machine. If that happens, please blow it dry and check insulation of machine.
5. If welding machine will not be used for long time, it must be put into the packing box and stored in dry and clean environment.

# TROUBLESHOOTING AND FAULT FINDING



Notes: The following operations must be performed by qualified electricians with valid certifications. Before maintenance, please contact with us for professional suggestion.

## 1. I-200c Premium/ I-250c fault symptom and remedy

Fault symptom	Remedy
<p>Power indicator is not lit, fan doesn't work, no welding output.</p>	<ul style="list-style-type: none"> <li>A. Make sure power switch is close.</li> <li>B. Make sure the electric wire net connecting to input cable is working alright</li> <li>C. Heat-sense resistance(4 pieces) is broken.(24V relay has problem)</li> <li>D. Power source board ( Bottom board has problem, no DC537V output voltage ):               <ul style="list-style-type: none"> <li>a) Silicon bridge circuit is broken, cable is loosen.</li> <li>b) Part of board is burnt.</li> <li>c) Check cable between air switch and the power source board, power board between MOS board.</li> </ul> </li> <li>E. Subsidiary power source on the control board has problem. (Contact with dealer or manufacturer.)</li> </ul>
<p>Fan is working and abnormal indicator is lit, no welding output.</p>	<ul style="list-style-type: none"> <li>A. Check if components are poor connects.</li> <li>B. Check if connector of output terminal is break circuit and poor connect.</li> <li>C. Inverter circuit may go wrong, please disconnect the power supply plug of the main transformer on MOS board (close to insert of fan VH-07) then restart the machine.               <ul style="list-style-type: none"> <li>a) If abnormal indicator is still on ,some fieldistors on MOS board are damaged ,find out and replace them with same model .</li> <li>b) If abnormal indicator is off:                   <ul style="list-style-type: none"> <li>1) Maybe transformer of middle board is damaged, measure primary inductance value and Q value of main transformer by inductance bridge.</li> <li>2) Primary value is parallel circuit, <math>L=1.2-2.0\text{mH}</math>, <math>Q&gt;40</math> If inductance value and Q value is low, replace it.</li> <li>3) Maybe some of secondary rectifier tube of transformer is broken, check and replace rectifier tube.</li> </ul> </li> </ul> </li> <li>D. Maybe feedback circuit is in fault.</li> </ul>